

Battery Carrier. Manufacturing and Mounting Instructions.

The construction is in Aluminium Alloy 2 mm thick and has been tested in accordance with 561e Section S for emergency landing conditions.

The two clips used to secure the battery carrier are stainless steel high grip hose clips. The battery carrier may be attached to the fuse tube when the aircraft is finished.

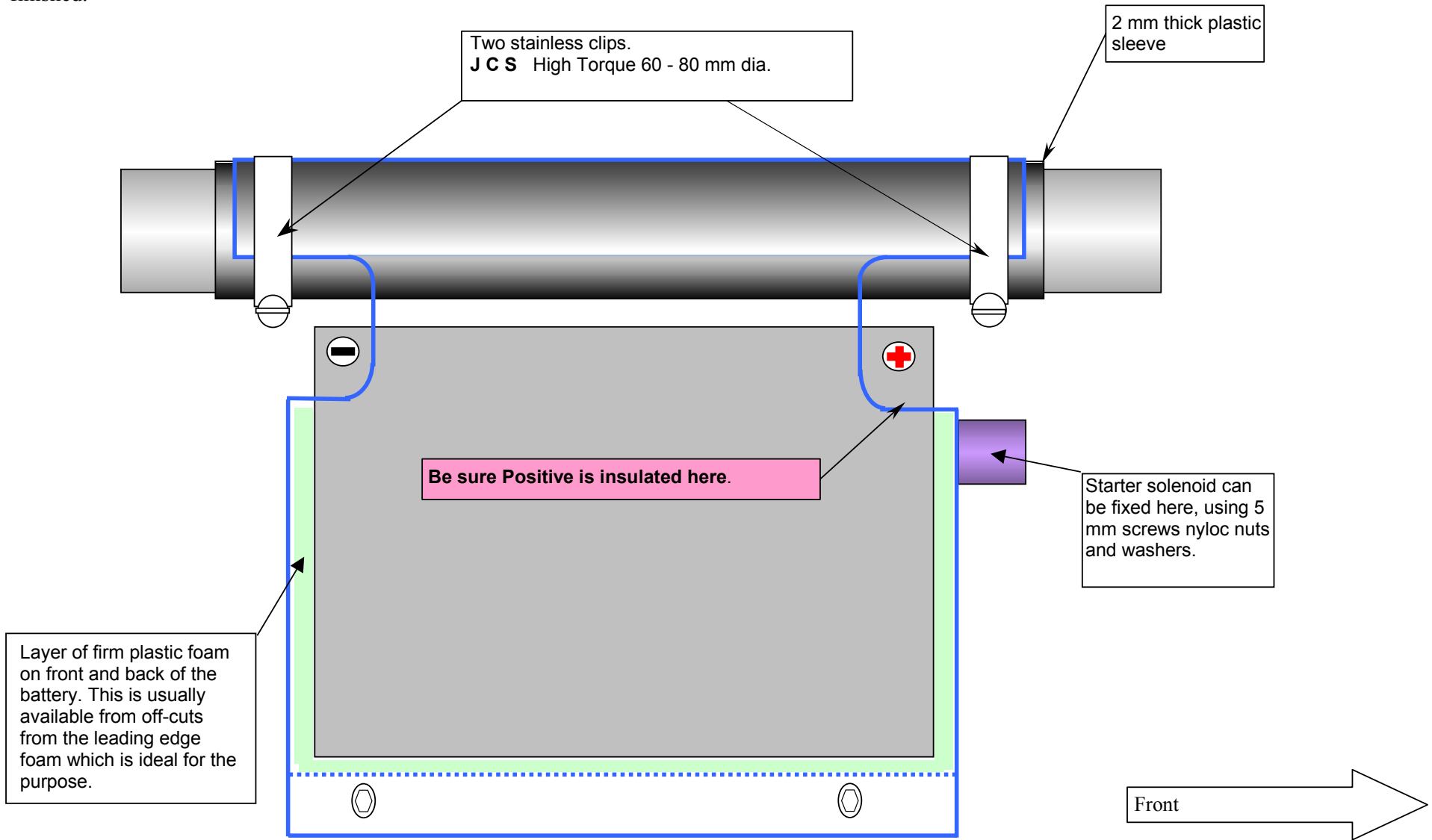

Mounting on fuselage tube when the position along the keel has been established.

- 1 Locate and fit the plastic protector by springing open and allowing it to snap onto the tube
- 2 The case, without the battery, is lightly sprung open, and fitted around the plastic protector from above.
- 3 Drill two 5 mm holes and fit the starter solenoid to the front end using 5 mm screws, nyloc nuts, and washers. The folds on the front are wider in order to accommodate the width of the starter solenoid bolt holes.
- 4 The battery, complete with it's foam sleeves is now located into the case. This is more easily achieved by inverting the battery, and the case, and assembling from above. Fit the bottom panel with four hexagon head screws, and nyloc nuts. Avoid having the battery as a heavy press fit in the box. It is better to have a little slack. **It may be necessary to flare the sides** of the box slightly to allow a slack fit, and give room for the foam. Tighten 5 mm bolts firmly.
- 5 Now revolve the assembly into the downward position, locate, and tighten the stainless steel clips to lock the whole assembly onto the fuselage tube.
- 6 Connect the positive to one side of the starter solenoid with your supply to the aircraft, and complete the rest of the wiring. Remember to ground the solenoid.

Leave the Negative Starter ground connection until all other wiring has been completed and checked. Do not use the airframe as an earth return.

Battery case material.

Material for the battery case may be made of any of the following specifications, as they all have approximately the same strengths and properties.

Aluminium Alloy's 5454 to BS 1470, 3103 to BS 1470, 5251 to BS 1470, 5154A to BS 1470, Generally standard aluminium sheet sold in metal stockists is ok..

It is recommended that aircraft type Duralumin Alloys be avoided i.e. 6082, 6061, as they are notoriously difficult to bend without proper equipment, and will crack or fracture at the bends during forming.

Wessex Light Aeroplane Co Ltd.

Drawing not to scale.

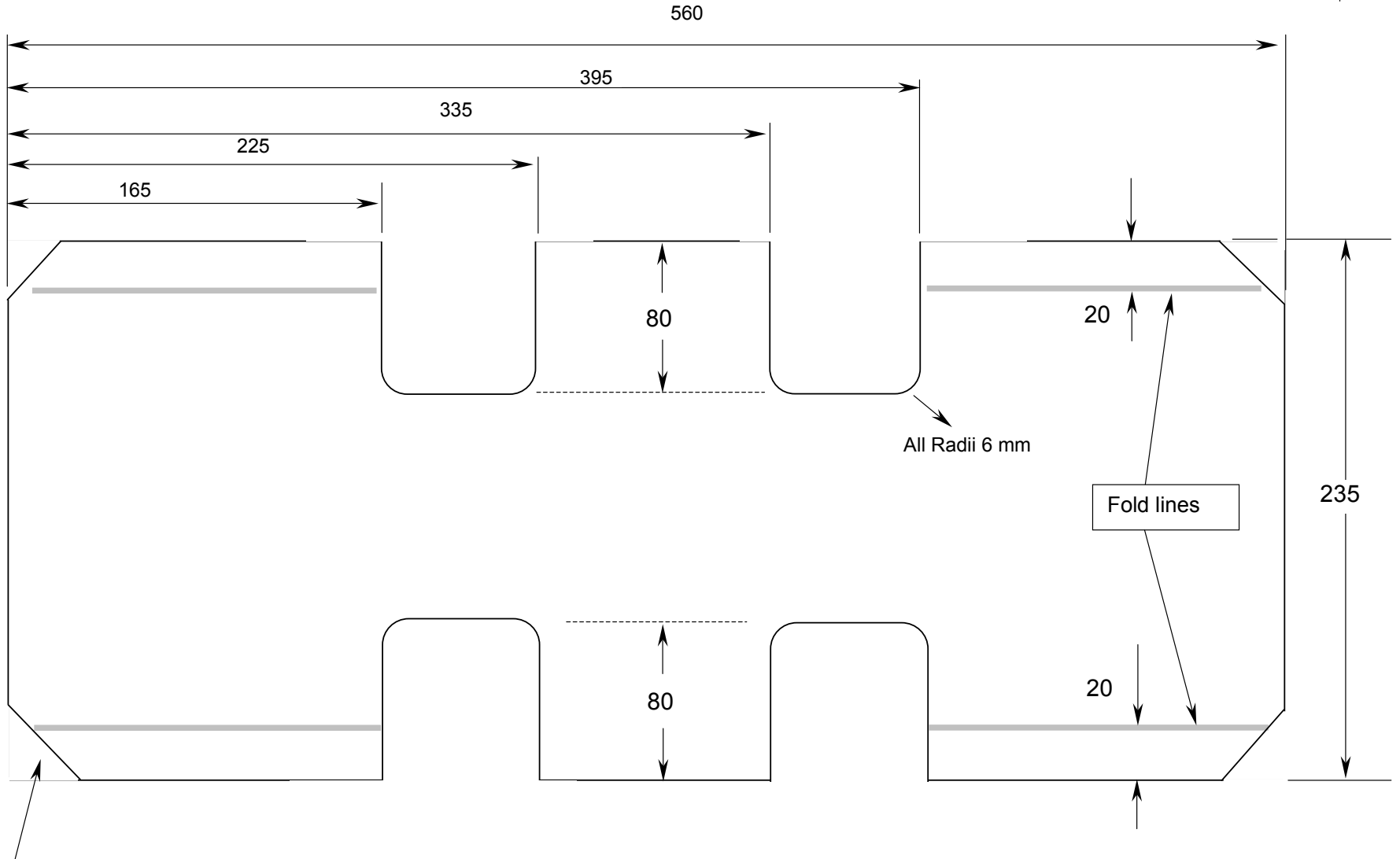
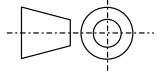

All chamfers 45 degrees.

Title	Battery Case Blank	Material	2 mm Alum Alloy Sht	All dimensions in mm	Tolerances	+ or - 2 mm	Drawing Number	1
-------	--------------------	----------	---------------------	----------------------	------------	-------------	----------------	---

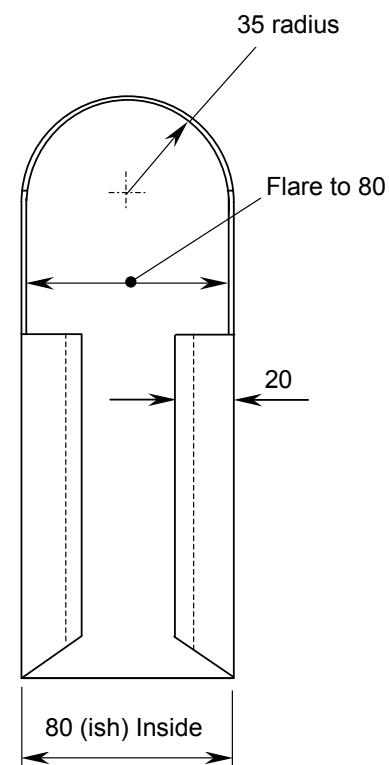
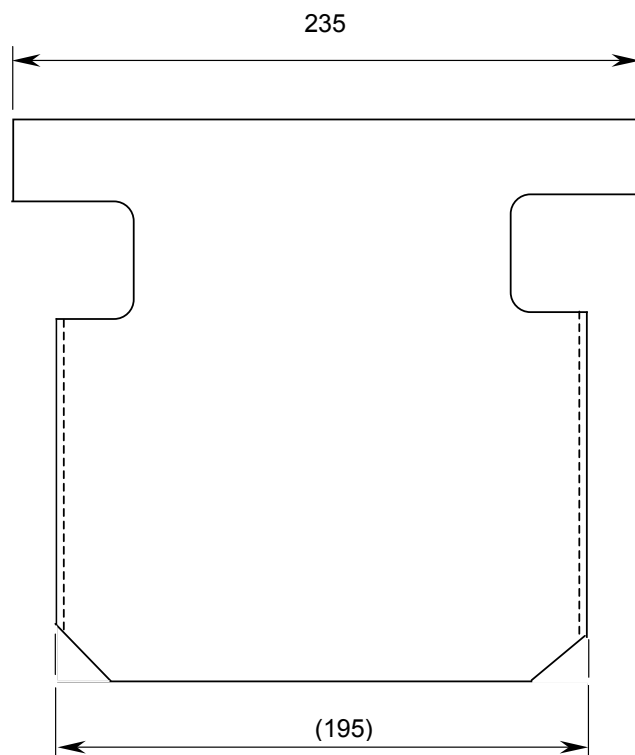
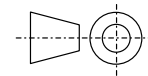

Note

These dimensions are for standard 12v 17ah Yuasa type Batteries
Adjust dimensions to suit alternative battery sizes.

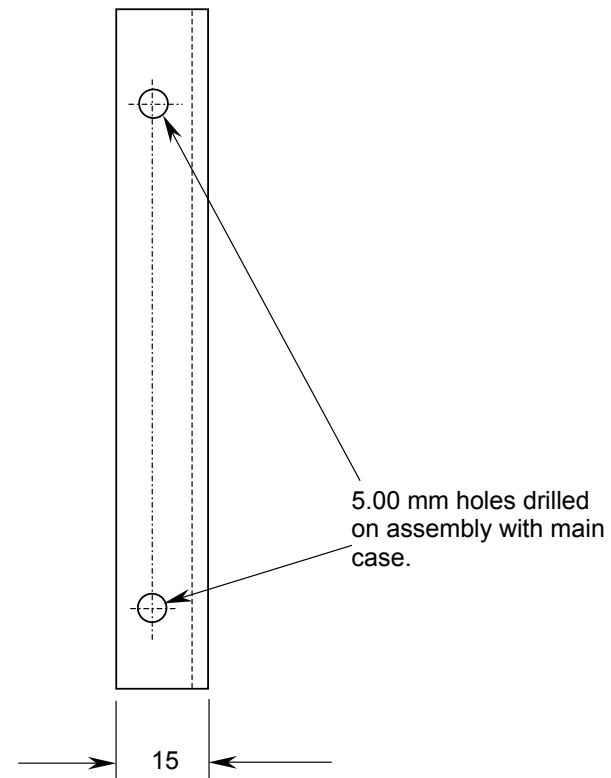
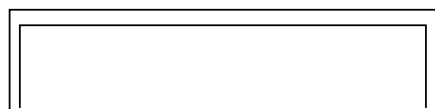
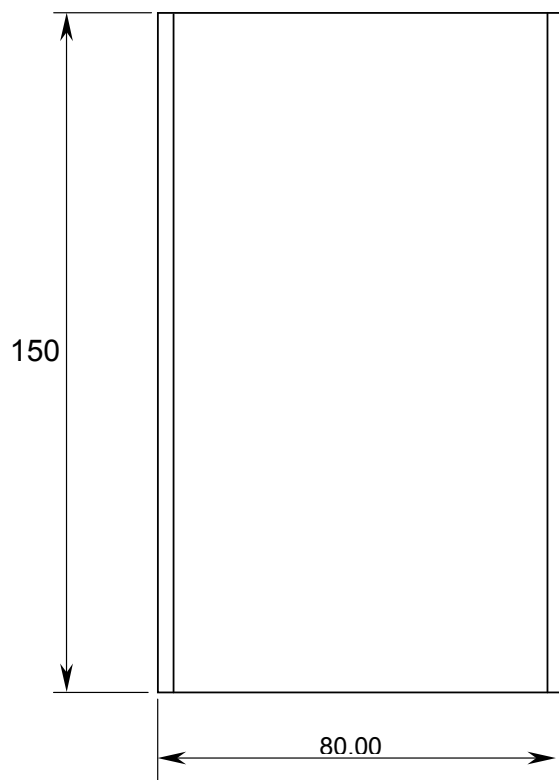
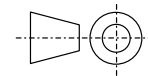

Internal radii 2 mm

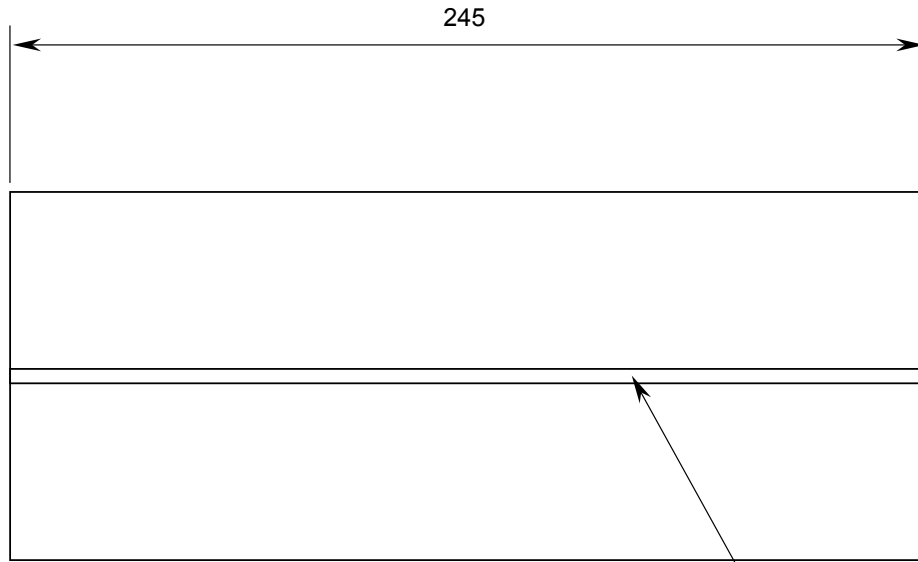
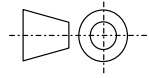

Hacksaw cut throughout length.

